



Bray[®]

SERIES 92/93 Rack & Pinion
Double Acting & Spring Return

PNEUMATIC ACTUATOR

SERIES 92/93

Styling, strength, compactness, and simplicity of design have been combined to produce the best rotary actuator on the market today. Bray Controls introduces this newest line of high performance, highest quality pneumatic actuators, the Series 92/93.

Engineering excellence and precision manufacturing has produced a modular product line with reduced overall size requirements and economic savings. In addition all Brayline Accessories are fully modular and directly mount to the actuator – providing flexibility and efficiency at reduced cost.

Bray Series 92/93 actuators are rack and pinion, opposed-piston actuators available in two versions: double acting for rotation of 90°, 135° and 180°, and spring return for 90° rotation. Their ideal use is actuating butterfly, ball or plug valves, but they can be applied anywhere a rotation of 90°, 135° or 180° is needed. Rotated on low friction acetal bearings, Bray units are well suited to handle offset loads to the gear and output shaft assembly.

The Series 92/93 actuators were designed primarily for pneumatic operation up to a maximum pressure of 140 psig (10 Bar) and for temperature ranges of -40°F (-40°C) to +200°F (+95°C). For higher and lower temperature applications, consult factory.

All double acting and spring return units are suitable for both on-off and throttling applications. Actuators which can be actuated with other media such as hydraulic oil or water are also available as an option.

The Series 92/93 is completely enclosed and self contained. The many features minimize maintenance and provide safe, simple disassembly and assembly.

The INTEGRAL PORTING (A) reduces the cost of external tubing that is also easily damaged. The unique, lubricated ACETAL PISTON GUIDES (B) and RINGS (C). Both have a very low coefficient of friction and absorb the side thrusts of the pistons. The piston cylinder walls in the body are honed to a very fine finish thus reducing the overall coefficient of friction. These features extend the life of the actuator and make the Series 92/93 one of the most efficient actuators on the market.

The OUTPUT SHAFT BEARINGS (D) on the top and bottom of the pinion are made of low-friction acetal.

The OUTPUT SHAFT and PINION GEAR (E) are one-piece, manufactured from hardened alloy steel and zinc-plated for corrosion protection.

The SHAFT POSITION INDICATOR (F) clearly shows open or closed position and is easily removable for MANUAL OVERRIDE FUNCTION of the actuator.

The BODY (G) is extruded aluminum with anodized corrosion protective coating. The END CAPS (H) are polyester coated for chemical resistance. This coating is resistant to dilute aqueous acids, salts, aliphatic hydrocarbons, detergents, petroleum solvents, alcohols, greases and oils.

The TRAVEL STOP (I) adjusting screws limit the travel of the actuator to specific degrees of rotation in both open and closed directions. The PISTONS (J) are die-cast aluminum.

The two PNEUMATIC SUPPLY PORTS (K) are 1/8" NPT on size 48 actuators. The other sizes have 1/4" NPT ports. NAMUR interface is standard on all actuator sizes.

All Bray Series 92/93 actuators have permanently lubricated factory packed bearings and guides. No further lubrication is necessary under normal operating conditions. All seals, including PISTON SEALS (L), are permanently lubricated Buna-N O-rings.

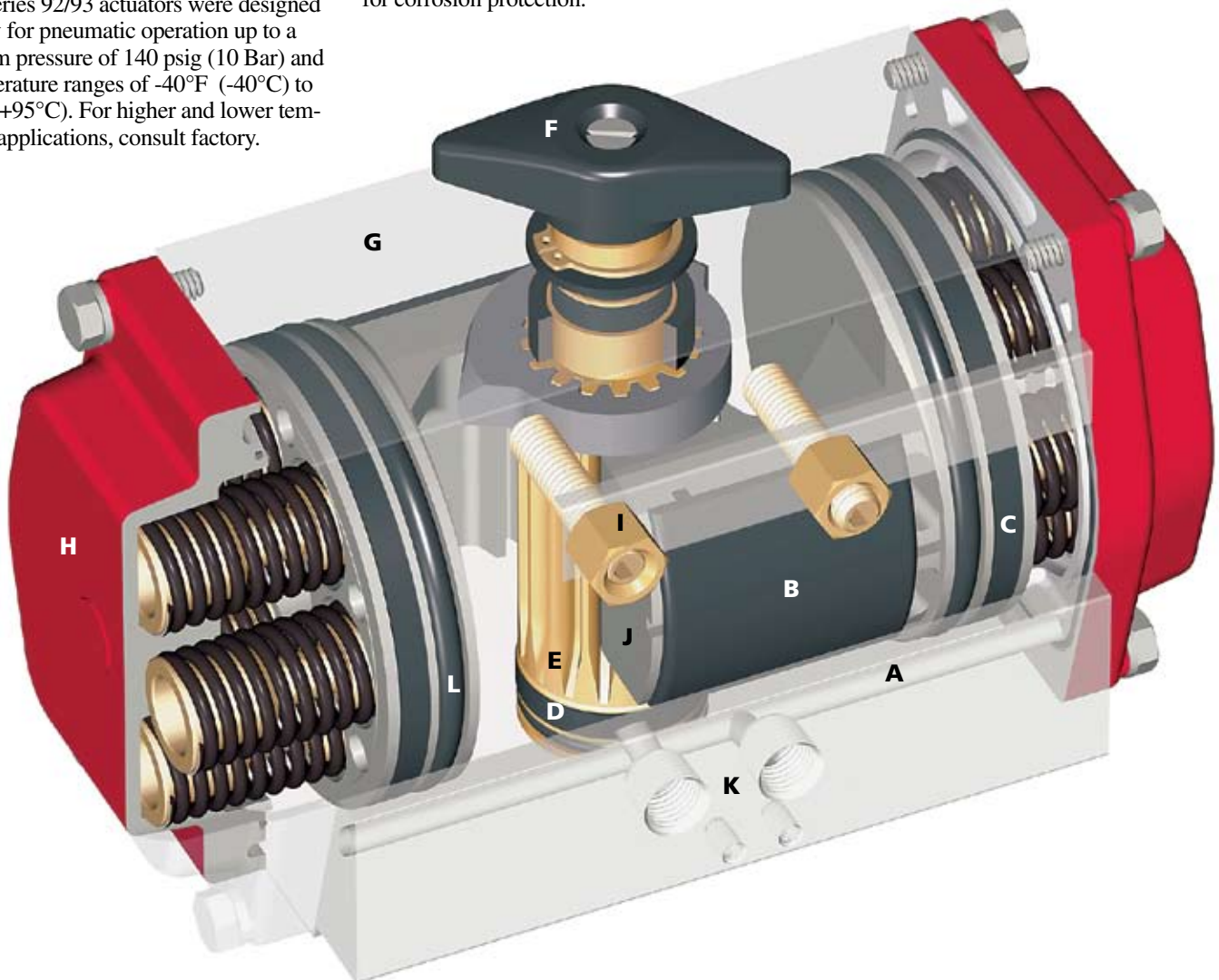

Double Acting/ Spring Return

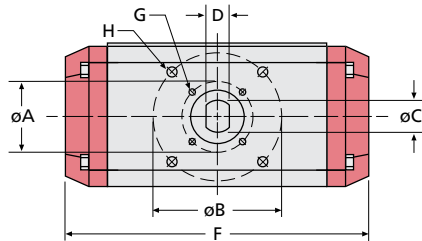
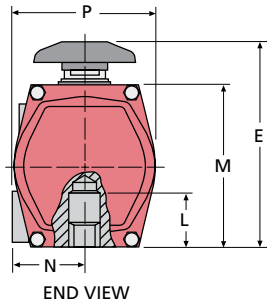
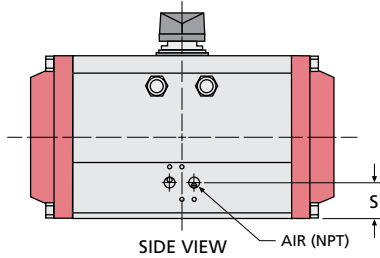
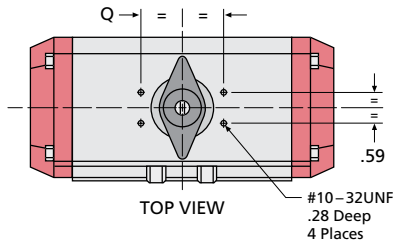

BOTTOM VIEW
ISO 5211 ACTUATOR
MOUNTING PATTERN

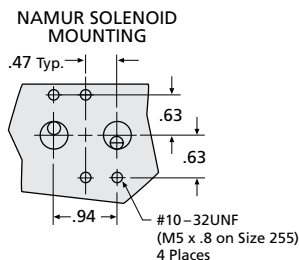
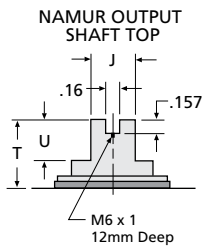

SERIES 92/93 DIMENSIONS

SIZE	48	63	83	92	118	127	160*	210	255‡
AIR NPT	1/8	1/4	1/4	1/4	1/4	1/4	1/4	1/4	1/4
A ISO "F"†	1.42 F 03	1.97 F 05	1.97 F 05	1.97 F 05	2.76 F 07	2.76 F 07	—	4.92 F 12	6.50 F 16
B ISO "F"†	1.97 F 05	2.76 F 07	2.76 F 07	2.76 F 07	4.92 F 12	4.92 F 12	4.92 F 12	6.50 F 16	7.87x4.72 Rect.
C	.55	.55	.75	.75	1.18	1.18	1.18	1.97	2.50
D	.40	.40	.51	.51	.87	.87	.87	.47	.62
E	3.88	4.53	5.43	5.78	7.28	8.09	9.36	11.45	13.35
F	6.10	5.58	7.40	8.59	11.90	12.31	15.54	17.80	26.70
G (UNC)	10-32 x .23	1/4-20 x .32	1/4-20 x .32	1/4-20 x .32	5/16-18 x .46	5/16-18 x .46	—	1/2-13 x .78	M16x2 x 28mm
H (UNC)	1/4-20 x .25	5/16-18 x .40	5/16-18 x .40	5/16-18 x .40	1/2-13 x .69	1/2-13 x .69	1/2-13 x .75	5/8-11 x 1.11	M16x2 x 28mm
J	.38	.38	.50	.50	1.12	1.12	1.12	1.12	1.12
L	1.38	1.38	1.46	1.46	2.20	2.20	2.20	2.76	4.25
M	2.50	3.46	4.27	4.61	5.52	6.32	7.80	10.04	11.89
N	1.60	1.72	2.02	2.18	2.53	2.72	3.07	4.25	4.75
P	2.78	3.11	3.83	4.17	4.91	5.44	6.82	8.83	10.75
Q	3.15	3.15	3.15	3.15	3.15	3.15	5.12	5.12	5.12
S	1.25	.89	.89	.94	1.36	1.36	1.39	1.44	1.50
T	1.10**	.79	.79	.79	.79	.79	1.18	1.18	1.18
U	.47	.47	.47	.47	.47	.47	.75	.75	.75

Note: Double Acting and Spring Return actuators have the same overall dimensions. The double acting unit of the size 48 actuator is optionally available with flat end caps with an F dimension of 4.00.

† ISO "F" means mounting flange-drilling pattern.

* Dimensions for Size 160A in table. Size 160B (keyed stem version) has C dimension of 1.38 and D dimension of .39.

‡ Dimensions for Size 255A in table. Size 255B actuator has a C dimension of 3.00 and D dimension of .75.

** Size 48 has a T dimension of .79 with use of NAMUR top plate.

Actuator Speeds

SIZE	48	63	83	92	118	127	160	210	255
Open Stroke/ Close Stroke	1/4	1/4	1/4	1/4	1/2	1/2	1	2	2 3/4

Note: Times shown are in seconds at 80 PSIG supply pressure with 6ft. tubing having an internal diameter of approximately 1/4". Bray S92/93 actuation times are very dependent on the flow capacity of their air supply. The use of smaller port solenoids, solenoid manifolds, smaller I.D. air supply tubing and/or extended lengths of tubing can significantly reduce the actuation time and/or initial response to the command signal.

Actuator Weights

SIZE	48	63	83	92	118	127	160	210	255
Double Acting	1.8	3.4	6.1	8.4	16.4	20.9	38.1	65.0	144.0
Spring Return	2.4	4.1	7.9	10.8	21.7	27.3	52.6	95.3	192.6

Weights are in lbs. Spring Return unit weights are with full set of springs per piston.

Actuator Volumes (ins³)

SIZE	48	63	83	92	118	127	160	210	255
Counter-clockwise	5.7	9.6	24.8	34.8	73.8	96.7	187.5	360.0	750.0
Clockwise	4.8	13.4	32.6	45.9	95.5	130.8	259.6	450.0	900.0

Counter-clockwise: Air volume in cubic inches required to push pistons apart, full travel.

Clockwise: Air volume in cubic inches required to push pistons together, full travel.

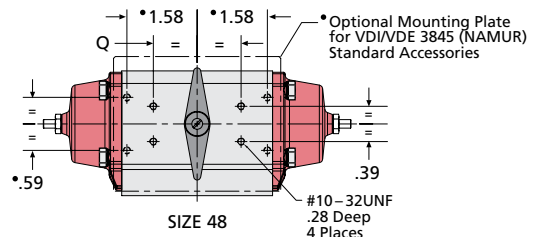
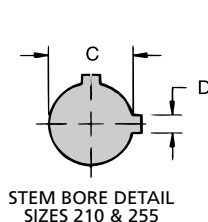

Special Note: Sizes 210 and 255 actuators have end-cap travel stops not bi-directional travel stops. Please consult factory for production release date of bi-directional stops for these size S92/93 actuators.

TORQUE

DOUBLE ACTING TORQUE CURVE

Series 92 – (Air to Air)

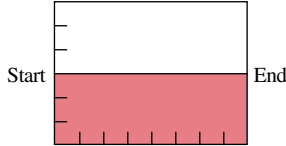

The Series 92 Actuator has a constant output torque throughout travel from start to end, clockwise or counterclockwise rotation.

SERIES 92 ACTUATOR TORQUE DATA

Double Acting Pneumatic Operated
Torque Output (Lb.-Ins.)

Actuator Size	Air Supply Pressure (PSIG)				
	40	60	80	100	120
48	75	113	150	188	225
63	145	221	297	373	449
83	351	536	721	906	1091
92	493	753	1013	1272	1532
118	1058	1615	2171	2728	3285
127	1410	2152	2894	3636	4378
160	2797	4270	5742	7214	8687
210	5783	8826	11870	14914	17957
255	14211	21691	29171	36650	44130

SINGLE ACTING TORQUE CURVES

Series 93 – (Spring Return)

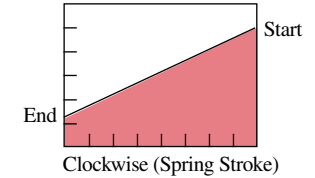
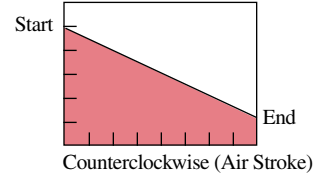

SERIES 93 ACTUATOR TORQUE DATA Air Operated, With Spring Return, Torque Output (Lb.-Ins.)

Actuator Size	No. Springs per Piston	Air Supply Pressure (PSIG)											
		40		60		80		100		120		Spring Stroke	
		Start	End	Start	End	Start	End	Start	End	Start	End	Start	End
48	1	51	32	89	70	126	107	164	145	201	182	43	24
	2/1	39	10	77	48	114	85	152	123	189	160	65	36
	2			64	27	101	64	139	102	176	139	86	49
	3/2			52	5	89	42	127	80	164	117	108	61
	3					77	21	115	59	152	96	129	73
63	2	91	65	167	141	243	217	319	293	395	369	80	54
	3	64	27	140	103	216	179	292	255	368	331	118	81
	4			113	65	189	141	265	217	341	293	156	108
	5			86	27	162	103	238	179	314	255	194	135
	6					135	65	211	141	287	217	232	162
83	2	210	167	395	352	580	537	765	722	950	907	184	141
	3	156	76	341	261	526	446	711	631	896	816	275	195
	4			281	176	466	361	651	546	836	731	360	255
	5			220	97	405	282	590	467	775	652	439	316
	6					369	185	554	370	739	555	536	352
92	2	310	232	570	492	830	752	1089	1011	1349	1271	261	183
	3	218	101	478	361	738	621	997	880	1257	1140	392	275
	4			386	231	646	491	905	750	1165	1010	522	367
	5			294	94	554	354	813	613	1073	873	659	459
	6					462	229	721	488	981	748	784	551
118	2	692	469	1249	1026	1805	1582	2362	2139	2919	2696	589	366
	3	509	174	1066	731	1622	1287	2179	1844	2736	2401	884	549
	4			883	437	1439	993	1996	1550	2553	2107	1178	732
	5			700	142	1256	698	1813	1255	2370	1812	1473	915
	6					1073	404	1630	961	2187	1518	1767	1098
127	2	880	465	1622	1207	2364	1949	3106	2691	3848	3433	945	530
	3			1357	733	2099	1475	2841	2217	3583	2959	1419	795
	4			1094	261	1836	1003	2578	1745	3320	2487	1891	1058
	5					1568	529	2310	1271	3052	2013	2365	1326
	6					1302	57	2044	799	2786	1541	2837	1592
160	2	1819	1118	3292	2591	4764	4063	6236	5535	7709	7008	1679	978
	3	1399	349	2872	1822	4344	3294	5816	4766	7289	6239	2448	1398
	4			2452	1123	3924	2595	5396	4067	6869	5540	3147	1818
	5			2030	353	3502	1825	4974	3297	6447	4770	3917	2240
	6					3154	1196	4626	2668	6099	4141	4546	2588
210	2	3833	2508	6876	5551	9920	8595	12964	11639	16007	14682	3275	1950
	3	2859	868	5902	3911	8946	6955	11990	9999	15033	13042	4915	2924
	4			4930	2275	7974	5319	11018	8363	14061	11406	6551	3896
	5			3949	638	6993	3682	10037	6726	13080	9769	8188	4877
	6					6022	2031	9066	5075	12109	8118	9839	5848
255	2	9487	6747	16967	14227	24447	21707	31926	29186	39406	36666	7464	4724
	3	7125	3015	14605	10495	22085	17975	29564	25454	37044	32934	11196	7086
	4			12243	6762	19723	14242	27202	21721	34682	29201	14929	9448
	5			9880	3030	17360	10510	24839	17989	32319	25469	18661	11811
	6					14998	6778	22477	14257	29957	21737	22393	14173



TRAVEL STOP Two independent adjusting screws are located on the center of the output shaft to precisely limit the travel of the actuator to specific degrees of rotation. The travel stops permit bidirectional adjustment of actuator movement in both the open and closed positions.



SPRING RETURN Bray's Series 93 spring return models employ a unique cartridge system. The actuator was designed to save both space and cost. The housing length of the spring return unit is the same as the double acting unit. Converting from double acting to spring return actuation is just a matter of removing the end caps and adding the unique spring cartridges. The actuator can be disassembled and assembled without cumbersome equipment or danger to the installer due to springs releasing. 40, 60, 80, and 100 psi services are standard, optional ratings are available.



DIRECT MOUNTING Bray actuators comply with ISO 5211 dimensions and mount directly to Bray valves without using external linkages. Field installation is simple, misalignment is minimized and contamination buildup between valve and actuator is reduced. Bray can provide linkage for mounting actuators to other devices requiring 90° to 180° rotation.

BrayLINE ACCESSORIES

SERIES 63 3-WAY AND 4-WAY SOLENOID VALVE

For electrical operation of pneumatic actuator on-off functions, Bray Series 63 solenoids are direct-mounted to the actuator by NAMUR interface. The pilot operated spool control valve is convertible from 3-Way (3/2) to 4-Way (5/2). Both watertight (NEMA 4, 4X) and explosion proof (NEMA 4, 4X, 7, 9) housings are standard. NPT and

IP65 DIN connections are offered with both single and dual coils. The air supply connection is 1/4" NPT and the electrical connection is 1/2" NPT. A manual override screw is located on the top of the valve body. Stainless Steel housings, digital Bus solenoids and a Series 55 speed control that allows independent control in both directions of travel are also available.



VALVE STATUS MONITOR

SERIES 50 The Series 50 signals actuator and valve position to local and remote stations. The compact valve status monitor mounts directly to the top of the actuator. Features include finger-touch control cams, captive cover bolts, local position indicator and two conduit entries for easy wiring. Rated for 15 amps at 125 or 250 volts AC, the Series 50 is provided with internal travel switches that are prewired to a terminal block. Standard switches are two single pole double throw (SPDT) micro switches. Available switch options are 4 micro switches, 2 proximity switches, 2 pneumatic switches or potentiometer for continuous read out. The housing is available in waterproof (NEMA 4, 4X) or explosion proof (NEMA 4, 4X, 7, 9).



SERIES 52 VALVE STATUS MONITOR

The Bray 2N1 ProxSensor provides 2 proximity sensors in 1 self-contained, fully sealed, compact enclosure. The sensors are completely encapsulated with epoxy resin in a polymer enclosure for superior moisture, chemical and corrosion protection. AC, DC, Intrinsically Safe and BUS Network versions are offered. Features include LED indicators, high visibility pointer for local position indication, non-magnetic targets and multi-pin electrical cable connector. A Valve Position Display is available as an option. AC Sensor units operate on 20-250 VAC with a maximum load current of 500mA. DC Sensor units operate on 10-30VDC with a maximum load current of 200mA. BUS Network powered units with solenoid drive are AS-i, DeviceNet and PROFIBUS DP.



SERIES 6A ELECTRO-PNEUMATIC POSITIONERS

Series 6A intelligent electro-pneumatic positioners offer precise, microprocessor driven flow control and advanced communication combined with the lowest air consumption on the market. For use with either double or single acting actuators, Series 6A positioners can accept an analog 4-20 mA, HART, Foundation Fieldbus or Profibus PA input signal. Features include an LCD display, keypad, auto calibration and adaptive control. Both waterproof (NEMA 4, 4X) and explosion proof (NEMA 4, 4X, 7, 9) housings are available.

Brayline Accessories and Bray Actuators both comply with VDI/VDE 3845 (NAMUR recommendations).

SPECIFICATIONS

SPACE SAVING MODULAR PRODUCT LINE

The actuator shall be pneumatically operated and must travel a minimum of 90° in each direction and must be able to overtravel at 3% in each direction past 90°. The actuator shall be totally enclosed and contained in a single enclosure, with no external moving parts. All pneumatic passage ways must be integral to the actuator housing so as to eliminate the need for external tubing. Actuator shall be rack and pinion design, and the output torque shall be linear throughout travel. Actuator shall be provided with pistons that have acetal piston guides and rings thus greatly extending the life of the actuator and reducing friction to the minimum. Actuator must be supplied with two independent travel stop adjustments, the 0° and 90° travel positions have travel adjustments of +5° to -5° (see Diagram A below). The actuator shall be provided with mechanical visual position indicator, and the indicator must be able to be removed easily thus exposing the output shaft for use of manually overriding the actuator when needed. The output

shaft and pinion must be of one piece and must be manufactured out of hardened alloy steel and zinc plated for corrosion protection. Actuator shall be able to mount in any position without loss of performance. The actuator shall bolt directly to Bray valve mounting flange without need for any brackets.

Actuator housing shall be anodized aluminum and all external fasteners shall be carbon steel, zinc plated. Springs shall be spring steel, coated for corrosion protection. All seals shall be Buna-N and bearings made of lubricated acetal resin.

The actuator shall be factory lubricated. Actuator design must have smooth housing lines so it will self-drain. The actuator shall be factory tested to ensure proper operation.

STANDARD MATERIALS

- Body: Extruded aluminum alloy, anodized
- End Caps: Die cast aluminum alloy with corrosion resistant polyester coating
- Pistons: Die cast aluminum alloy
- Output Shaft/Pinion: Carbon Steel, zinc plated
- Travel Stop: Alloy Steel
- Shaft Bearings: Acetal
- Piston Guides: Acetal
- Fasteners: Stainless Steel
- Springs: Spring Steel, protective coating
- O-Ring Seals: Buna-N
- Options: Polyester coated body exterior
Electroless Nickel plated body exterior
Hard Anodized body exterior
Stainless Steel pinion

SPRING RETURN – MODULAR DESIGN

The Spring Return System for fail-safe services must be installed in the same housing as the double acting actuator, with no additional housing extensions required, therefore saving weight and space. The spring system must be supplied as a self-contained spring cartridge system. This is a safety feature that ensures disassembly of the actuator without danger of spring release when end caps are removed. Actuator shall be Bray Series 92 or 93 or approved equal.

SERVICE DATA:

Actuators shall be designed for pneumatic operation up to a maximum pressure of 140 PSIG (10 Bar) and for temperature ranges of -40°F (-40°C) to +200°F (+95°C). Filtered air is recommended but not required. All double acting and spring return units shall be suitable for both on-off and throttling applications. Optional units shall be able to operate with other media such as hydraulic oil or water, consult factory for further information.

OPTIONAL EQUIPMENT

See Bray brochure #1030 for Solenoid, brochures #1011 and #1029 for Pneumatic and Electro-Pneumatic Positioners and brochures #1012 and #1015 for Valve Status Monitors.

Diagram A Travel Stop Adjustments

The 0° and 90° travel positions have travel adjustments of +5° max. to -5° min.

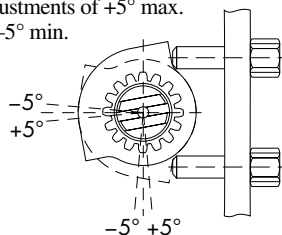

Caution: Care should be taken not to over adjust the travel stops in too far or out too far.

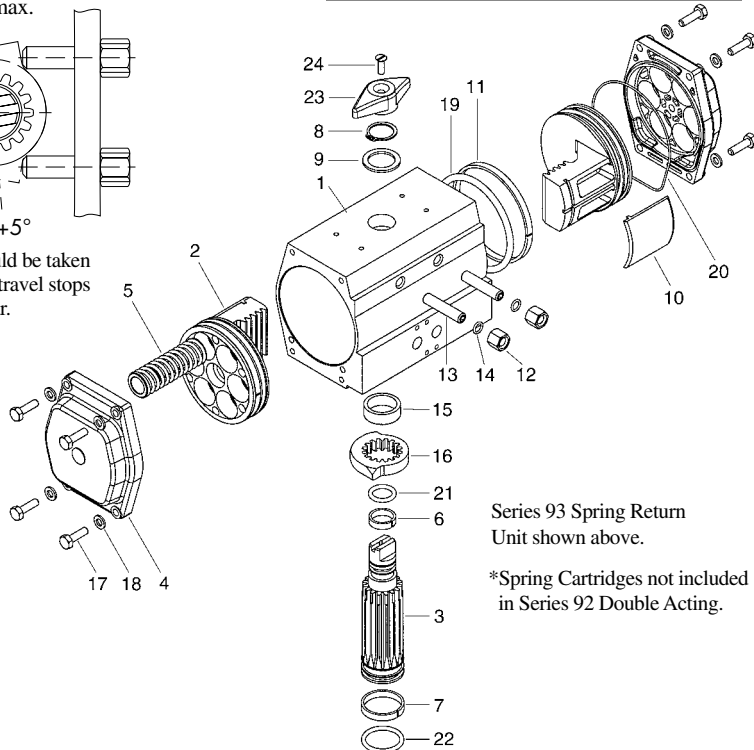

Series 93 Spring Return Unit shown above.

*Spring Cartridges not included in Series 92 Double Acting.

ACTUATOR COMPONENTS

Item No.	Qty.	Description
1	1	Body
2	2	Piston
3	1	Pinion
4	2	End Cap
5*	12 max.	Spring Cartridge Assembly
6	1	Upper Bearing
7	1	Lower Bearing
8	1	Retaining Ring
9	1	Nylon Washer
10	2	Acetal-Bearing Pad
11	2	Acetal-Guide Ring
12	2	Stop Nut
13	2	Travel Adjusting Screw Stop
14	2	O-Ring-Travel Stop
15	1	Acetal Spacer
16	1	Travel Stop
17	8	Hex Head Cap Screw
18	8	Washer
19	2	O-Ring-Piston
20	2	O-Ring-End Cap
21	1	O-Ring-Shaft-Top
22	1	O-Ring-Shaft-Bottom
23	1	Indicator Pointer
24	1	Indicator Pointer Screw

DISTRIBUTOR



All statements, technical information, and recommendations in this bulletin are for general use only. Consult Bray representatives or factory for the specific requirements and material selection for your intended application. The right to change or modify product design or product without prior notice is reserved.

Patented and patents applied for all over the world. Bray® is a registered trademark of BRAY INTERNATIONAL, Inc.

Bray CONTROLS

A Division of BRAY INTERNATIONAL, Inc.
13333 Westland East Blvd. Houston, Texas 77041
281.894.5454 FAX 281.894.9499 www.bray.com

© 2007 Bray International. All rights reserved.

B-1032 04/07